

# NMQB(X)24-1

On/Off, Non-Spring Return, 24 V



Technical Data	NMQB(X)24-1
Power supply	24 VAC $\pm 20\%$ 50/60 Hz 24 VDC $\pm 10\%$
Power consumption	13 W (1.5 W)
Transformer sizing	23 VA (Class 2 power source) (I max 20A@5ms)
Electrical connection	3 ft [1m] 10 ft [3m] 16 ft [5m] 18 GA plenum rated cable protected NEMA 2 (IP54)
Overload protection	electronic throughout 0 to 95° rotation
Control	on/off
Input impedance	100 $\Omega$
Angle of rotation	min. 30°, max. 95°, adjust. with mechanical stop
Torque	70 in-lb [10 Nm]
Direction of rotation	reversible with  switch
Position indication	reflective visual indicator (snap-on)
Manual override	external push button
Running time	4, 10 or 15 seconds constant independent of load
Humidity	5 to 95% RH non-condensing (EN 60730-1)
Ambient temperature	-22°F to 122°F [-30°C to 50°C]
Storage temperature	-40°F to 176°F [-40°C to 80°C]
Housing	NEMA 2, IP54, UL enclosure type 2
Housing material	UL94-5VA
Agency listings	cULus acc. to UL 60730-1A/-2-14, CAN/CSA E60730-1:02, CE acc. to 2004/108/EEC and 2006/95/EC
Noise level	<52 dB(A)
Servicing	maintenance free
Quality standard	ISO 9001
Weight	1.8 lbs [0.85 kg]

Rated Impulse Voltage 800V, Type of action 1, Control Pollution Degree 3.

Torque min. 70 in-lb for control of damper surfaces up to 17 sq ft.

## Application

For On/Off control of dampers in HVAC systems. Actuator sizing should be done in accordance with the damper manufacturer's specifications.

The actuator is mounted directly to a damper shaft up to 1.05" in diameter by means of its universal clamp, 1/2" self-centered default. A crank arm and several mounting brackets are available for applications where the actuator cannot be direct coupled to the damper shaft.

## Operation

The actuator is not provided with and does not require any limit switches, but is electronically protected against overload. The anti-rotation strap supplied with the actuator will prevent lateral movement.

The NMQB(X) series provides 95° of rotation and a visual indicator indicates position of the actuator. When reaching the damper or actuator end position, the actuator automatically stops. The gears can be manually disengaged with a button on the actuator cover.

The NMQB(X)24-1 actuators use a sensorless brushless DC motor, which is controlled by an Application Specific Integrated Circuit (ASIC). The ASIC monitors and controls the actuator's rotation and provides a digital rotation sensing (DRS) function to prevent damage to the actuator in a stall condition. Power consumption is reduced in holding mode.

Add-on auxiliary switches or feedback potentiometers are easily fastened directly onto the actuator body for signaling and switching functions.

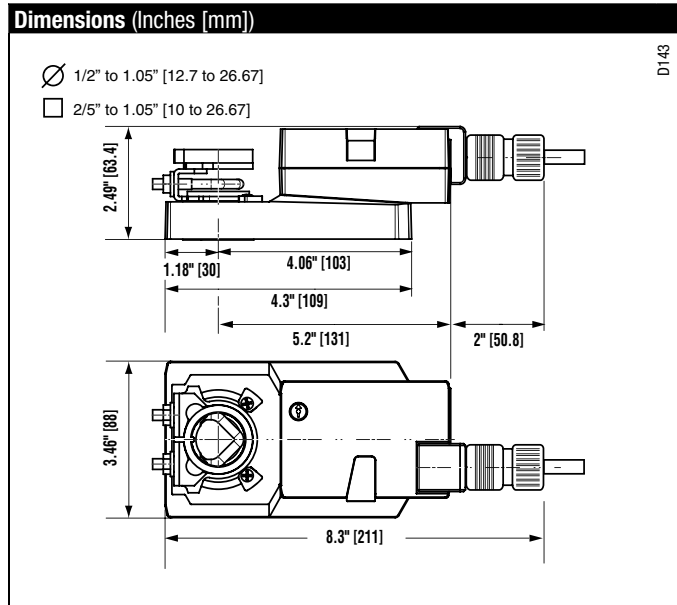

IM40024 - 05/10 - Subject to change. © Belimo Aircontrols (USA), Inc.

### Accessories

K-NA	Reversible Clamp
ZG-100	Universal Mounting Bracket
ZG-101	Universal Mounting Bracket
ZG-103	Universal Mounting Bracket
ZG-104	Universal Mounting Bracket
ZG-NMA	Crank arm Adaptor Kit
AV8-25	Universal Shaft Extension
ZG-NMSA-1	Shaft Adaptor
ZS-T	Terminal Cover for NEMA 2
ZS-100	Weather Shield - Steel
ZS-150	Weather Shield - Polycarbonate
Tool-06	8 mm & 10 mm Wrench
S1A, S2A	Auxiliary Switch (es)
P370	Shaft Mount Auxiliary Switch
P...A	Feedback Potentiometers

**NOTE:** When using NMQB(X)24-1 actuators, only use accessories listed on this page.

### Typical Specification

On/Off control damper actuators shall be electronic direct-coupled type, which require no crank arm and linkage and be capable of direct mounting to a shaft up to 1.05" diameter. Actuators shall have brushless DC motor technology and be protected from overload at all angles of rotation. Actuators shall have reversing switch and manual override on the cover. Run time shall be constant and independent of torque. Actuators shall be cULus listed, have a 5-year warranty, and be manufactured under ISO 9001 International Quality Control Standards. Actuators shall be as manufactured by Belimo.

### Wiring Diagram

#### ✂️ INSTALLATION NOTES

⚠️ 1 Provide overload protection and disconnect as required.

⚠️ 3 Actuators may also be powered by 24 VDC.

#### 📄 APPLICATION NOTES

◆ Meets cULus or UL and CSA Standard requirements without the need of an electrical ground connection.

#### ⚠️ WARNING Live Electrical Components!

During installation, testing, servicing and troubleshooting of this product, it may be necessary to work with live electrical components. Have a qualified licensed electrician or other individual who has been properly trained in handling live electrical components perform these tasks. Failure to follow all electrical safety precautions when exposed to live electrical components could result in death or serious injury.

