



- Fast quarter turn open or closed operation
- Stainless steel ball and stem
- Positive shut-off
- Two-piece body construction

### Application

- Water-side control of air handling apparatus in ventilation and air-conditioning system
- Water/Steam control in heating systems
- 300:1 rangeability

The dimensions and drilling of end flanges conform to the American cast iron flange standard, Class 150 (ANSI B16.1).

### Technical Data

Media	chilled or hot water, glycol, 250# steam
Flow characteristic	equal percentage
Action	90% rotation valve open CW, valve closed CCW
Sizes	3", 4", 6"
Type of end fittings	flanged

### Materials:

Body	Carbon Steel
Ball	Stainless Steel with Hardened Chrome Plating
Seats	Teflon
Stem	Stainless Steel
Packing	Spring-loaded Teflon

Pressure rating	ANSI 150
Media temp. range	-22°F to 400°F (-30°C to 204°C)
Close-off pressure	150 psig @ 400°F
Maximum differential pressure (ΔP)	steam: 100psi water: 150psi

Cv	Valve Nominal Size		Type	Suitable Actuators		
	Inches	DN [mm]	2-way NPT	Spring	Electronic Fail-Safe	Non-Spring
207	3"	80	B6300VB-207	AF		GM AM Series
350	4"	100	B6400VB-350		GK	
507	6"	150	B6600VB-507			GM SY Series

# AMX24-MFT-X1

Multi-Function Technology



Technical Data	AMX24-MFT-X1, AMX24-MFT95-X1
Power supply	24 VAC ± 20% 50/60 Hz 24 VDC ± 10%
Power consumption	4 W (1.25 W)
Transformer sizing	6 VA (class 2 power source)
Electrical connection	3 ft [1m] 10 ft [3m] 16 ft [5m] 18 GA plenum rated cable ½" conduit connector
Overload protection	electronic throughout 0° to 95° rotation
Input impedance	100 kΩ for 2 to 10 VDC (0.1 mA) 500 Ω for 4 to 20 mA 750 Ω for PWM 1500 Ω for on/off and floating point
Feedback	2 to 10 VDC, 0.5 mA max VDC variable
Angle of rotation	max 95°, adjustable with mechanical stop electronically variable
Torque	180 in-lb [20 Nm]
Direction of rotation	reversible with  switch
Position indication	reflective visual indicator (snap-on)
Manual override	external push button
Running time	150 seconds (default) variable (90 to 350 seconds)
Humidity	5 to 95% RH non-condensing (EN 60730-1)
Ambient temperature	-22° F to 122° F [-30° C to 50° C]
Storage temperature	-40° F to 176° F [-40° C to 80° C]
Housing	NEMA type 2/IP54
Housing material	UL94-5VA
Agency listings	cULus according to UL 60730-1/-2-14, CAN/CSA E60730-1, CSA C22.2 No. 24-93, CE according to 89/336/EEC
Noise level	<45 db(A)
Servicing	maintenance free
Quality standard	ISO 9001

## Dimensions with 2-Way Valve

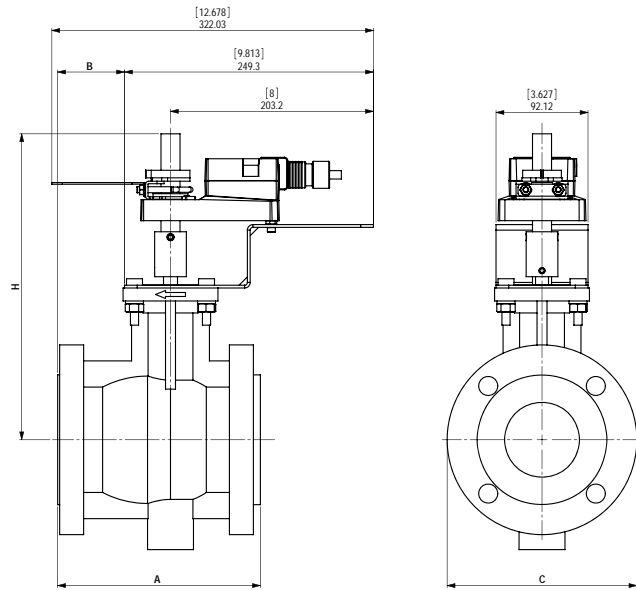

Valve Body	COP	Valve Nominal Size		Dimensions (Inches)			
		Inches	DN [mm]	A	B	C	H
B2100VB-024	150	1"	25	5.00	1.37	2.75	10.07
B2150VB-055	150	1½"	40	7.00	2.51	3.42	10.47
B2200VB-077	150	2"	50	7.00	2.51	3.93	11.14
B6300VB-207	150	3"	80	8.00	2.64	7.48	12.05

M40025 - 05/10 - Subject to change. © Belimo Aircontrols (USA), Inc.

## Wiring Diagrams

- 1 Provide overload protection and disconnect as required.
- 3 Actuators may also be powered by 24 VDC.
- 4 Position feedback cannot be used with Triac sink controller. The actuator internal common reference is not compatible.
- 5 Control signal may be pulsed from either the Hot (source) or the Common (sink) 24 VAC line.
- 6 ZG-R01 may be used.
- 7 Contact closures A & B also can be triacs. A & B should both be closed for triac source and open for triac sink.
- 8 For triac sink the common connection from the actuator must be connected to the hot connection of the controller.



## APPLICATION NOTES



Meets cULus or UL and CSA requirements without the need of an electrical ground connection.



### WARNING Live Electrical Components!

During installation, testing, servicing and troubleshooting of this product, it may be necessary to work with live electrical components. Have a qualified licensed electrician or other individual who has been properly trained in handling live electrical components perform these tasks. Failure to follow all electrical safety precautions when exposed to live electrical components could result in death or serious injury.

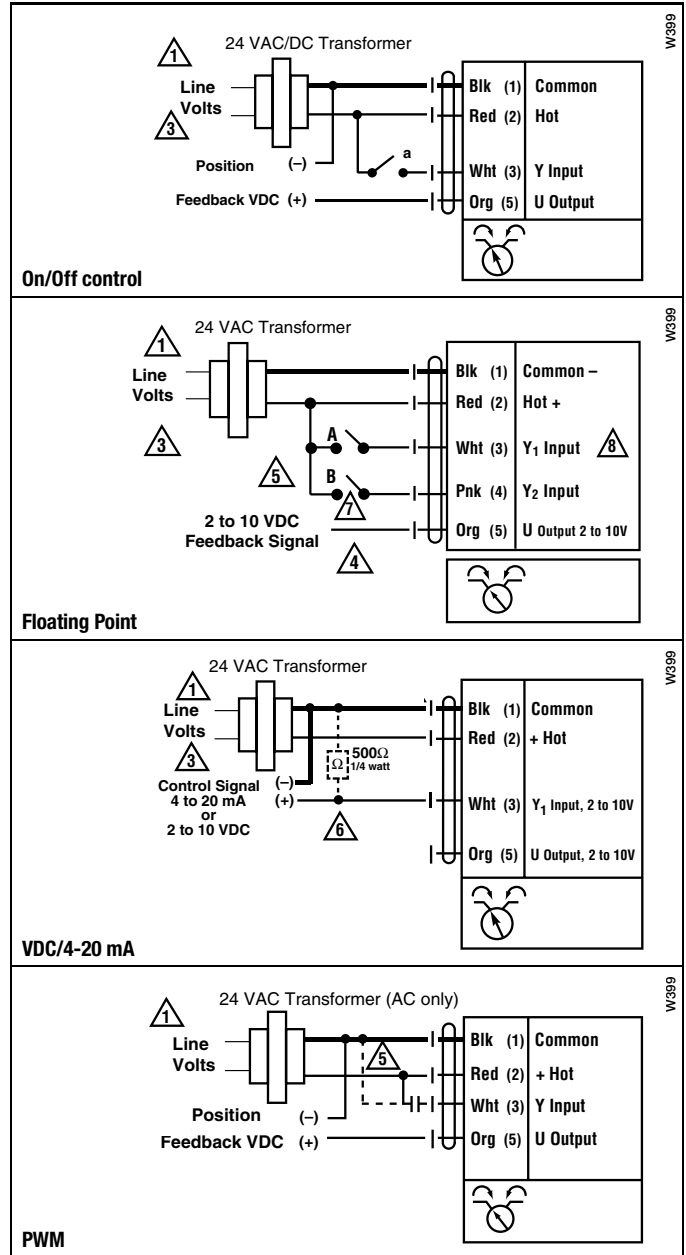

### INSTALLATION NOTES

- 21 Provide overload protection and disconnect as required.
- 22 Actuators and controller must have separate transformers.
- 23 Consult controller instruction data for more detailed information.
- 24 Resistor value depends on the type of controller and the number of actuators. Honeywell® resistor kits may also be used.
- 25 To reverse control rotation, use the reversing switch.

### Override

Switch A	Switch B	Damper Position
		Damper Open
		Damper Closed

The direction of rotation switch is set so that the fail safe position and the position of the damper is closed with no signal at wire R.

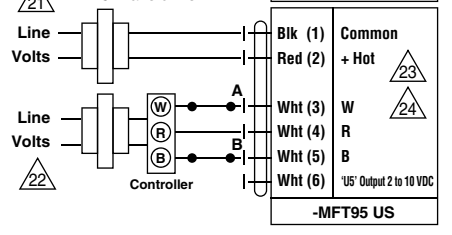
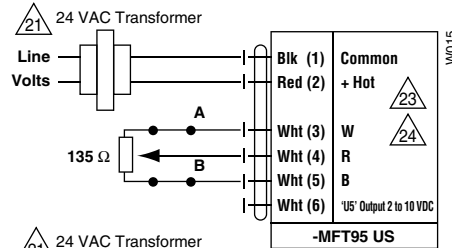

### Low Limit Control

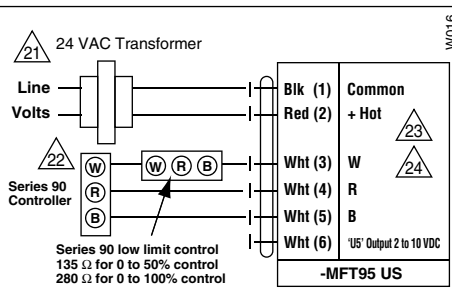

### High Limit Control

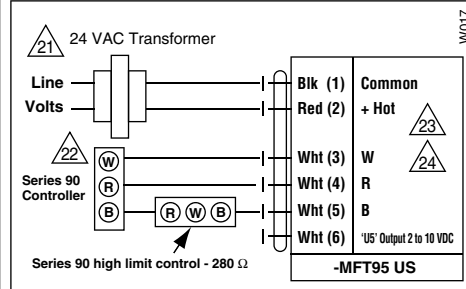

### Wiring Multiple Actuators to a Series 90 Controller

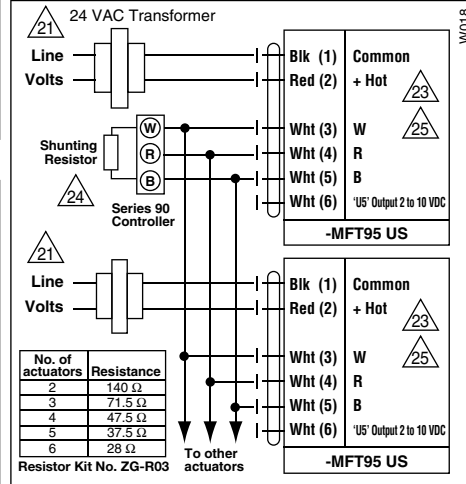

### Wiring Multiple Actuators to a Series 90 Controller using a Minimum Position Potentiometer

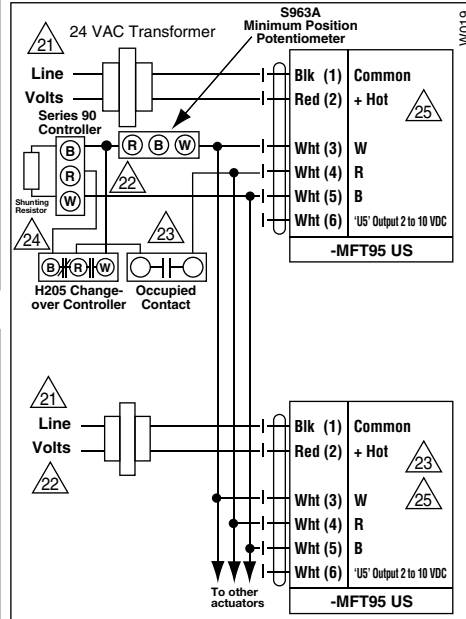

### Typical wiring diagrams for multiple actuators used with the W973, W7100 and T775 controllers

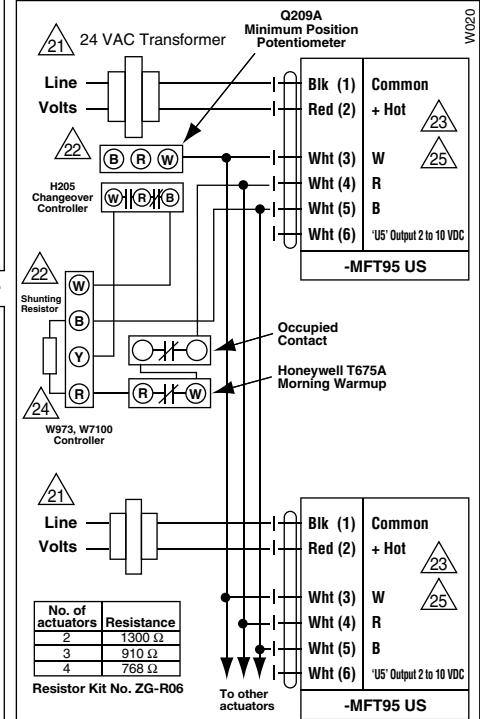

Used with the W973 and W7100 controllers

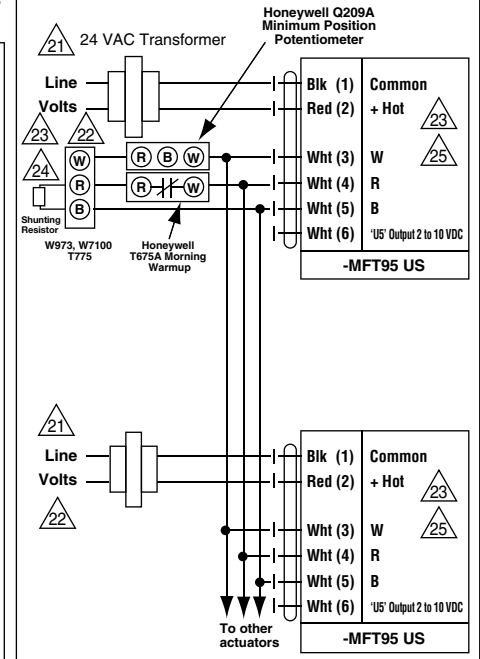

## Valve Installation Procedure

### 3", 4" & 6" Valves - Flanged Installation

1. Valve must be in the closed position for installation.
2. **Figure 1 illustrates a flanged valve installation.**
3. Use hex bolts & nuts to secure valve to flange.
4. Ensure proper gaskets are used between the valve flange and pipe flange.
5. Tighten bolts & nuts in alternating opposite sides until completely tightened. Please see torque requirements below. Torque wrench is required.

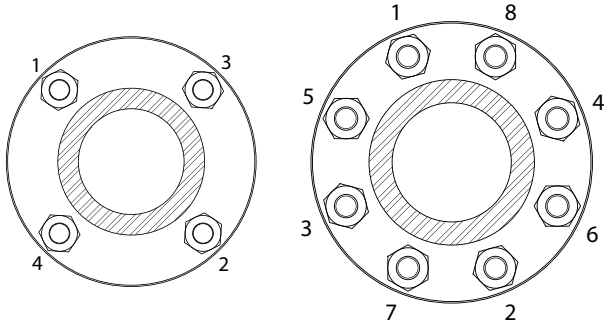

3" Bolt Tightening Sequence

4" & 6" Bolt Tightening Sequence



**WARNING:** Exceeding the Maximum Torque Can Damage the Valve and Void the Warranty!

- 3" ANSI 150 Flange - 65 ft/lbs
- 4" ANSI 150 Flange - 70 ft/lbs
- 6" ANSI 150 Flange - 100 ft/lbs

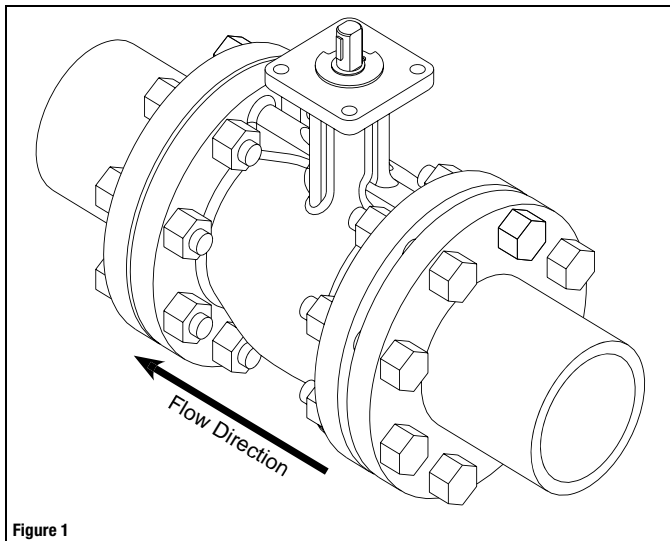

Figure 1

## Seat Replacement Procedure

### 3", 4" & 6" Valves

1. Remove valve from pipe
2. Remove 2 cap retaining washers (1)
3. Using 2 wrenches/flat-head screwdrivers, pry cap assembly (2) out of valve
4. Rotate valve to fully open position
5. Using hands, pull seat (3) out of the valve
6. Replace seat and reverse procedure to reassemble
7. Reinstall valve per installation instructions

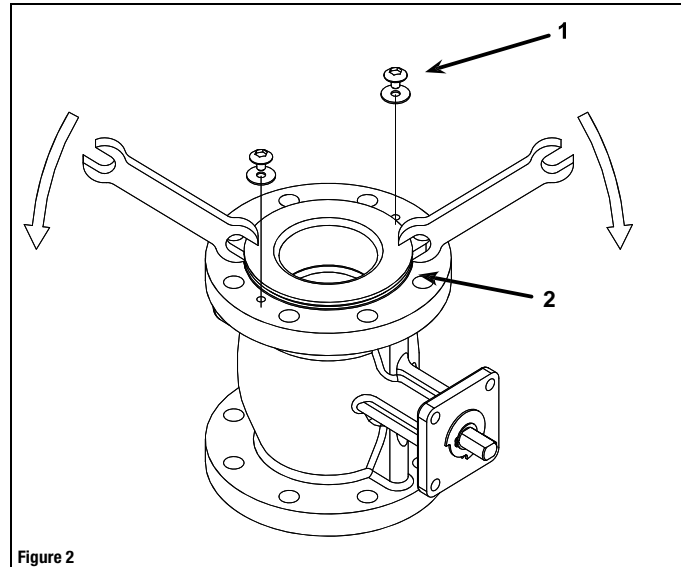

Figure 2

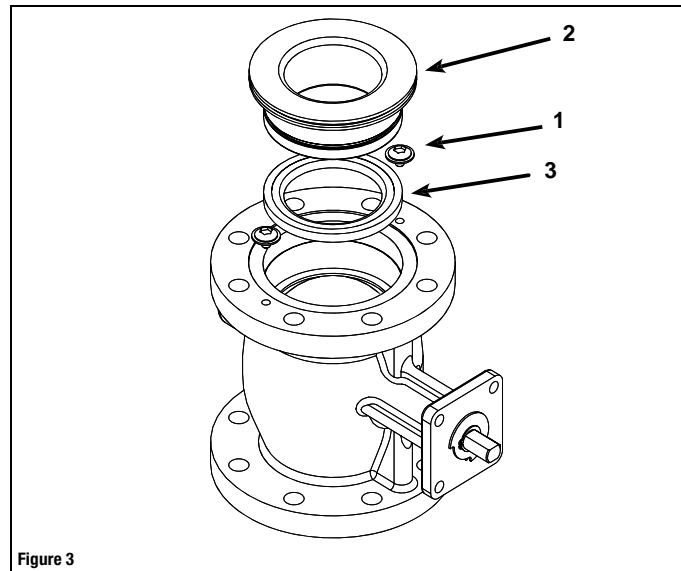

Figure 3