

G6...(S) 2-way Flanged Globe Valve, Bronze or Stainless Steel Trim



Technical Data		
	G6...	G6...S
Service	chilled or hot water, 60% glycol, steam	chilled or hot water, 60% glycol, steam
Flow characteristic	modified equal percentage	
Action	stem up - open A to AB	
Sizes	2½" to 3"	
End fitting	125 lb. flanged	
Materials		
Body	iron	iron
Seat	bronze	stainless steel
Stem	stainless steel	stainless steel
Plug	bronze	stainless steel
Packing	NLP (no lip packing)	TFE V-ring
ANSI class	ANSI 125	
Leakage	Class III	
Max inlet		
Steam	35 psi (241kPa)	50 psi (345kPa)- NV 100 psi (680kPa)- Rotary
Water	150 psi (1034kPa) @ 250°F	150 psi (1034kPa) @ 250°F
Media temperature		
Water	32°F to 350°F (0°C to 176°C)	32°F to 350°F (0°C to 176°C)
Steam	32°F to 280°F (0°C to 138°C)	32°F to 298°F - NV (0°C to 148°C) 32°F to 338°F - Rotary (0°C to 170°C)
Maximum ΔP*		
Water	25 psi (172kPa)	50 psi (345kPa)
Steam	15 psi (103kPa)	50 psi (345kPa)
Rangeability	50:1	
Valve weights	G665(S) 55 lbs G680(S) 72 lbs G6100(S) 119 lbs	

* (50% or more open)

G6...(S) 2-way Flow Patterns

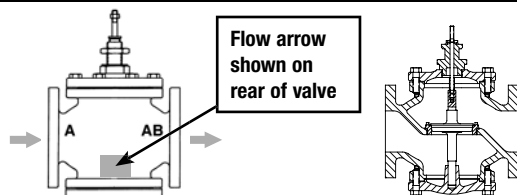

Flow Pattern is marked on valve.

Stem Up - Open A to AB

Application

This valve is typically used in Large Air Handling Units on heating or cooling coils. This valve is suitable for use in a hydronic system with variable flow.

Bronze or stainless steel trim valves can be used for steam applications, depending on actuator and close-off combination.

Cv	Valve Nominal Size Inches	Type 2-way Flanged	Suitable Actuators			Electronic Fail-Safe
			Non-Spring	Spring		
65	2½	G665(S)	NVG	GM	AF AFX	GK
90	3	G680(S)				
170	4	G6100(S)				

Dimensions

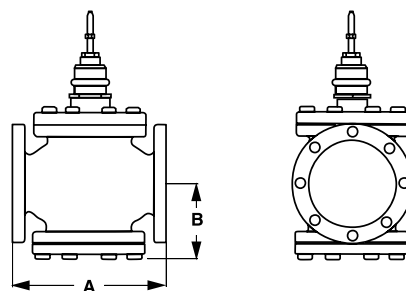

D166-2WF

Valve Body	Valve Nominal Size		Dimensions (Inches [mm])	
	Inches	DN [mm]	A	B
G665(S)	2½"	[65]	9" [229]	4.75" [120]
G680(S)	3"	[80]	10" [254]	5.37" [137]
G6100(S)	4"	[100]	13" [330]	6.37" [162]

Piping

The valves should be mounted in a weather-protected area in a location that is within the ambient limits of the actuator. Allow sufficient room for valve with actuator and for service. For the NV Series, allow 6" for cover removal and 12" for complete actuator removal. The G6/G7 preferred mounting position of the valve is with the valve stem vertical above the valve body, for maximum life. However, the assemblies can be mounted with valve stem vertical above the valve or up to 45 degrees in relation to the horizontal pipe. The actuators should never be mounted underneath the valve, as condensation can build up and result in a failure of the actuators. Do not reverse flow direction.



MFT



Models

AFX24-MFT-X1
AFX24-MFT-S-X1 w/built-in Aux. Switch

Technical Data

Power supply	24 VAC, +/- 20%, 50/60 Hz 24 VDC, +20% / -10%
Power consumption♦	running 7.5 W holding 3 W
Transformer sizing♦	10 VA (Class 2 power source)
Electrical connection	3 ft [1m], 10 ft [3m] or 16 ft [5m] 18 GA appliance or plenum cables, with or without ½" conduit connector -S models: two 3 ft [1m], 10 ft [3m] or 16 ft [5m] appliance cables with or without ½" conduit connectors
Overload protection	electronic throughout 0 to 95° rotation
Operating range Y*	2 to 10 VDC, 4 to 20 mA (default) variable (VDC, PWM, floating point, on/off)
Input impedance	100 kΩ for 2 to 10 VDC (0.1 mA) 500 Ω for 4 to 20 mA 1500 Ω for PWM, floating point and on/off control
Feedback output U*	2 to 10 VDC, 0.5 mA max
Torque	minimum 180 in-lb (20 Nm)
Direction of rotation*	spring reversible with cw/ccw mounting motor reversible with built-in switch
Mechanical angle of rotation*	95° (adjustable with mechanical end stop, 35° to 95°)
Running time	spring <20 seconds @ -4°F to 122°F [-20° C to 50° C]; <60 seconds @ -22°F [-30° C] motor* 150 seconds (default), variable (70 to 220 seconds)
Angle of rotation adaptation	off (default)
Override control*	min position = 0% mid. position = 50% max. position = 100%
Position indication	visual indicator, 0° to 95° (0° is spring return position)
Manual override	5 mm hex crank (9/16" Allen), supplied
Humidity	max. 95% RH, non-condensing
Ambient temperature	-22 to 122° F (-30 to 50° C)
Housing	NEMA 2, IP54, Enclosure Type 2
Housing material	zinc coated metal and plastic casing
Noise level	≤40dB(A) motor @ 150 seconds, run time dependent ≤62dB(A) spring return
Agency listings †	cULus acc. to UL60730-1A/-2-14, CAN/CSA E60730-1:02, CE acc. to 2004/108/EC & 2006/95/EC
Quality standard	ISO 9001
Weight	4.2 lbs. (1.9 kg), 4.3 lbs. (2 kg) with switch

* Variable when configured with MFT options

† Rated Impulse Voltage 800V, Type of action 1.AA (1.AA.B for -S version), Control Pollution Degree 3.

♦ Programmed for 70 sec motor run time. At 150 sec motor run time, transformer sizing is 8.5 VA and power consumption is 6 W running / 3 W holding.

AFX24-MFT-S-X1

Auxiliary switches	2 x SPDT 3A (0.5A) @ 250 VAC, UL approved one set at +10°, one adjustable 10° to 90°
--------------------	---

Dimensions with G2...(S) Series 2-Way Valve

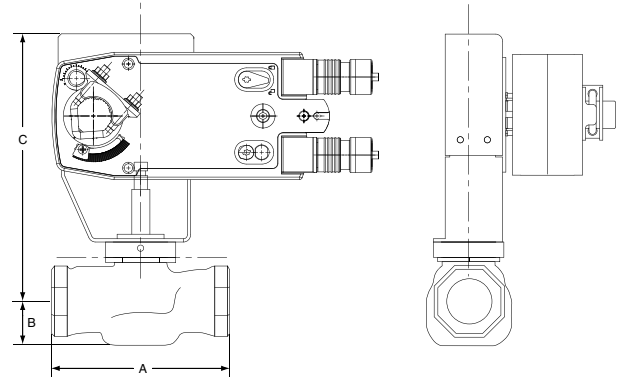

Valve Body	Valve Nominal Size		Dimensions (Inches [mm])		
	Inches	DN [mm]	A	B	C
G2(S)	1½"	40	5.37" [137]	1.50" [38]	8.50" [216]
G2(S)	2"	50	6.12" [156]	1.56" [40]	8.56" [217]

Dimensions with G3...(D) Series 3-Way Valve

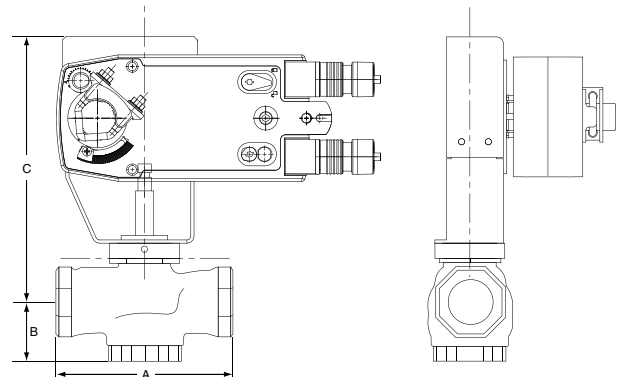

Valve Body	Valve Nominal Size		Dimensions (Inches [mm])		
	Inches	DN [mm]	A	B	C
G3(D)	1½"	40	5.37" [137]	1.62" [41]	8.62" [219]
G3(D)	2"	50	6.12" [156]	1.87" [48]	8.87" [225]

Dimensions with G6/G6C ANSI 125 and G6 ANSI 250 Series 2-Way Valve

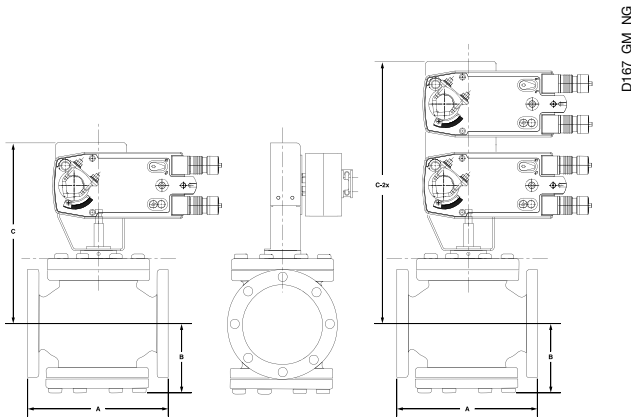

Dimensions with G7 and G7D ANSI 125/250 Series 3-Way Valve

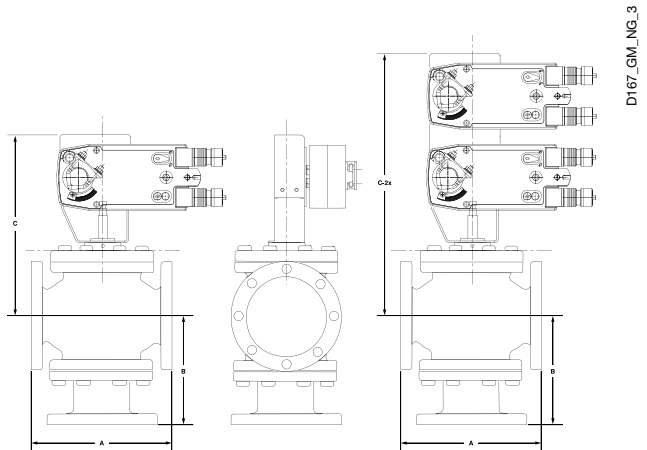

Valve Nominal Size Dimensions (Inches [mm])

Valve Body	Inches	DN [mm]	A	B	C
G6 ANSI 125	2½"	65	9.00" [229]	4.75" [121]	13.50" [343]
G6 ANSI 125	3"	80	10.00" [254]	5.37" [136]	13.94" [354]
G6 ANSI 250	2½"	65	9.62" [244]	4.75" [121]	14.00" [356]
G6 ANSI 250	3"	80	10.75" [273]	5.37" [136]	14.12" [359]
G6C ANSI 125	2½"	65	9.00" [220]	4.75" [121]	13.50" [343]
G6C ANSI 125	3"	80	10.00" [254]	5.37" [136]	13.94" [354]
G6C ANSI 250	2½"	65	9.62" [244]	4.75" [121]	13.50" [343]
G6C ANSI 250	3"	80	10.75" [254]	5.37" [136]	13.94" [354]

Valve Nominal Size Dimensions (Inches [mm])

Valve Body	Inches	DN [mm]	A	B	C
G7 & G7D ANSI 125	2½"	65	9.00" [229]	7.12" [181]	13.87" [352]
G7 & G7D ANSI 125	3"	80	10.00" [254]	8.00" [203]	14.43" [367]
G7D ANSI 125	4"	100	13.00" [330]	9.87" [251]	15.25" [387]
G7 & G7D ANSI 250	2½"	65	9.62" [244]	7.37" [187]	14.00" [356]
G7 & G7D ANSI 250	3"	80	10.75" [273]	8.37" [213]	14.62" [371]
G7D ANSI 250	4"	100	13.62" [346]	10.25" [260]	15.25" [387]

Valve Nominal Size Dimensions (Inches [mm])

Valve Body	Inches	DN [mm]	A	B	C-2x
G6 ANSI 125	2½"	65	9.00" [229]	4.75" [121]	18.25" [464]
G6 ANSI 125	3"	80	10.00" [254]	5.37" [136]	19.18" [487]
G6 ANSI 250	2½"	65	9.62" [244]	4.75" [121]	18.25" [464]
G6 ANSI 250	3"	80	10.75" [273]	5.37" [136]	19.18" [487]
G6C ANSI 125	4"	100	13.00" [330]	6.87" [175]	20.25" [514]
G6C ANSI 125	5"	125	15.75" [400]	7.87" [200]	20.87" [530]
G6C ANSI 125	6"	150	17.75" [451]	8.50" [216]	21.50" [546]
G6C ANSI 250	4"	100	13.62" [346]	6.87" [175]	20.25" [514]
G6C ANSI 250	5"	125	16.62" [422]	7.87" [200]	20.87" [530]
G6C ANSI 250	6"	150	18.62" [473]	8.50" [216]	21.50" [546]

Valve Nominal Size Dimensions (Inches [mm])

Valve Body	Inches	DN [mm]	A	B	C-2x
G7 ANSI 125	2½"	65	9.00" [229]	7.12" [181]	18.25" [464]
G7 ANSI 125	3"	80	10.00" [254]	8.00" [203]	19.18" [487]
G7 ANSI 125	4"	100	13.00" [330.2]	9.87" [251]	20.00" [508]
G7D ANSI 125	5"	125	12.00" [305]	10.50" [267]	18.37" [467]
G7D ANSI 125	6"	150	14.12" [359]	11.12" [282]	19.18" [487]
G7 ANSI 250	2½"	65	9.62" [244]	7.37" [187]	18.75" [476]
G7 ANSI 250	3"	80	10.75" [273]	8.37" [213]	19.37" [492]
G7 ANSI 250	4"	100	13.62" [346]	10.25" [260]	20.37" [517]
G7D ANSI 250	5"	125	12.87" [327]	11.00" [279]	20.56" [522]
G7D ANSI 250	6"	150	14.50" [368]	11.50" [292]	21.25" [540]

N40021 - 06/11 - Subject to change. © Belimo Aircontrols (USA), Inc.

Wiring Diagrams

INSTALLATION NOTES

- 1 Provide overload protection and disconnect as required.
- 2 **CAUTION Equipment Damage!**
Actuators may be connected in parallel if not mechanically mounted to the same shaft. Power consumption and input impedance must be observed.
- 3 Actuators may also be powered by 24 VDC.
- 4 Position feedback cannot be used with Triac sink controller.
- 5 The actuator internal common reference is not compatible.
- 6 Control signal may be pulsed from either the Hot (source) or the Common (sink) 24 VAC line.
- 7 Contact closures A & B also can be triacs.
- 8 A & B should both be closed for triac source and open for triac sink.
- 9 For triac sink the common connection from the actuator must be connected to the hot connection of the controller.

APPLICATION NOTES

Meets UL requirements without the need of an electrical ground connection.

The ZG-R01 500 Ω resistor may be used.

WARNING Live Electrical Components!
During installation, testing, servicing and troubleshooting of this product, it may be necessary to work with live electrical components. Have a qualified licensed electrician or other individual who has been properly trained in handling live electrical components perform these tasks. Failure to follow all electrical safety precautions when exposed to live electrical components could result in death or serious injury.

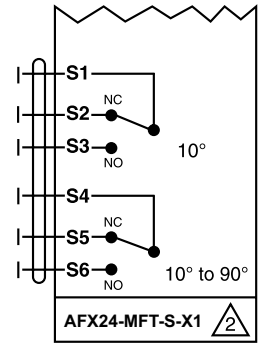

Auxiliary Switches for AFX24-MFT-S-X1

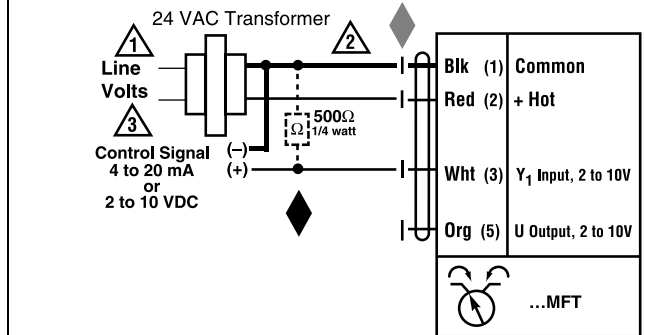

VDC/4-20 mA

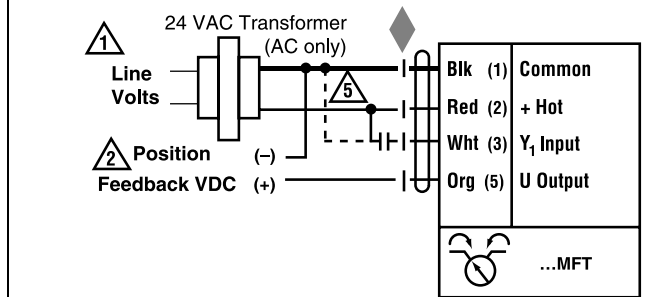

PWM

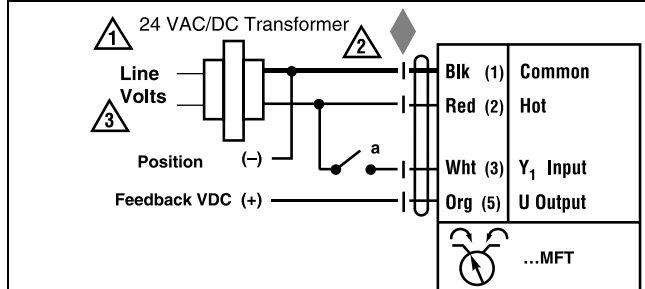

On/Off control

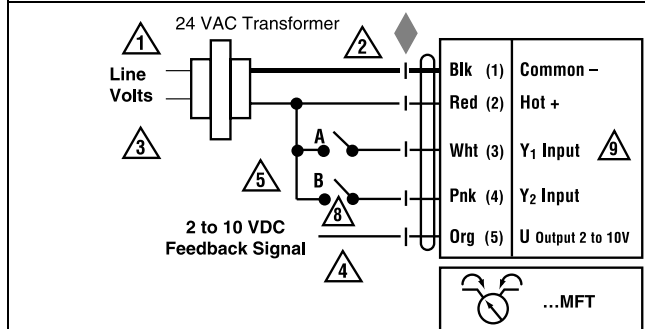

Floating Point control

	Non-Spring Return				Spring Return					Electronic Fail-Safe
	NV	NVG	GM	2 x GM	NVF	AF	2x AF	AFX	2 x AFX	GK
2-way ANSI 125										
G665, G665S		62	113	150		36	59	51	82	113
G680, G680S		42	78	121		24	40	34	56	78
G6100, G6100S			19							19
2-way Pressure Comp ANSI 125										
G665C, G665CS, G665LCS	150				150	150		150		
G680C, G680CS, G680LCS	150				136	150		150		
G6100C, G6100CS, G6100LCS			150				132		150	150
G6125C, G6125CS, G6125LCS			150				87		150	150
G6150C, G6150CS, G6150LCS			150				50		150	150
2-way Pressure Comp ANSI 250										
G665C-250, G665CS-250								250		
G680C-250, G680CS-250								250		
G6100C-250, G6100CS-250			250						212	250
G6125C-250, G6125CS-250			239						152	239
G6150C-250, G6150CS-250			178						105	178
2-way ANSI 250										
G665-250, G665S-250		62	113	176		36	59	51	82	113
G680-250, G680S-250		42	78	121		24	40	34	56	78
G6100-250, G6100S-250			19							19
3-way ANSI 125 Mixing										
G765, G765S		62	113	150		36	59	51	82	114
G780, G780S		42	78	121		24	40	34	56	78
G7100, G7100S			19	31					13	19
G7125, G7125S				19						
G7150, G7150S				13						
3-way ANSI 250 Mixing										
G765-250, G765S-250		62	113	176		35	58	40	114	114
G780-250, G780S-250		42	78	121		23	40	25	77	78
G7100-250, G7100S-250				31					24	19
G7125-250, G7125S-250				19						
G7150-250, G7150S-250				13						
3-way ANSI 125/250 Diverting										
G765D, G765DS, G765DS-250		100	100			100		100		100
G780D, G780DS, G780DS-250		100	100			100		100		100
G7100D, G7100DS, G100DS-250		100	100			100		100		100
G7125D, G7125DS, G7125DS-250			100				100		100	100
G7150D, G7150DS, G7150DS-250			100				100		100	100

N40021 - 06/11 - Subject to change. © Belimo Aircontrols (USA), Inc.